

MEETING TABLES

design office



MFC TOPS

30mm easy to clean scratch-resistant anti-reflective melamine faced chipboard (MFC) top finished with 2mm matching straight ABS impact resistant edges. Panel density: 670/730 kgs per cubic meter

Finish options:

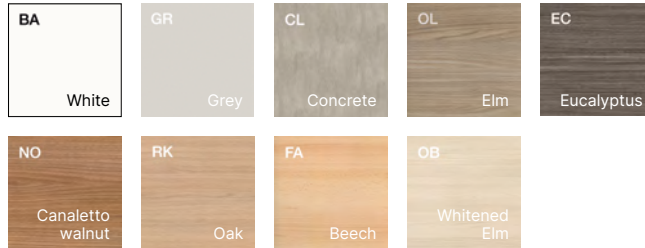

GLASS TOPS

12mm tempered back painted safety glass top finished with 1.5mm 45° polished edges.

Finish options:

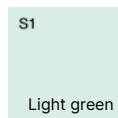

BASE



Steel trumpet base leg made of a cone-shaped column (140mm max dia, 100mm min dia) and a Ø590mm 6mm steel molded base complete with seal to prevent marking. Metal plate linking top to the base. All parts supplied epoxy powder coated.

Finish options:

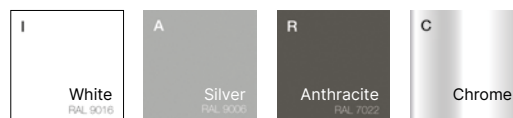

LAYOUT

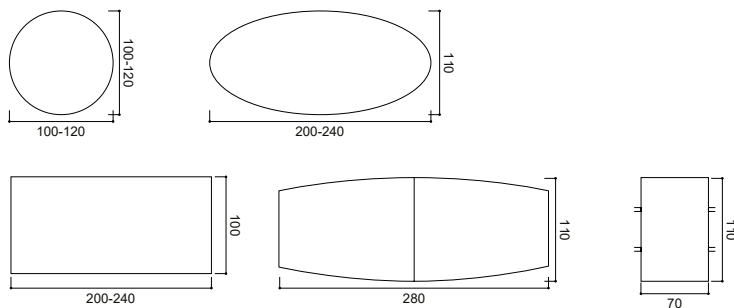

MFC TOPS

30mm easy to clean scratch-resistant anti-reflective melamine faced chipboard (MFC) top finished with 2mm matching straight ABS impact resistant edges. Panel density: 670/730 kgs per cubic meter

Finish options:

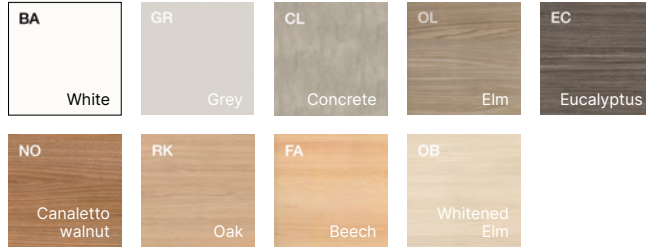

BASE

40x40mm legs and crossbar made from trapezoidal 1.5mm steel tube, zamak feet. Metal plates screw to the top. All metal parts supplied epoxy powder coated.



Finish options:



ø60mm chrome
Abs 0-8mm
adjustable levelling
feet.

LAYOUT

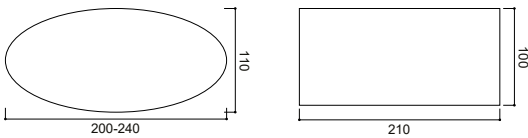

MFC TOPS

30mm easy to clean scratch-resistant anti-reflective melamine faced chipboard (MFC) top finished with 2mm matching straight ABS impact resistant edges. Panel density: 670/730 kgs per cubic meter

Finish options:

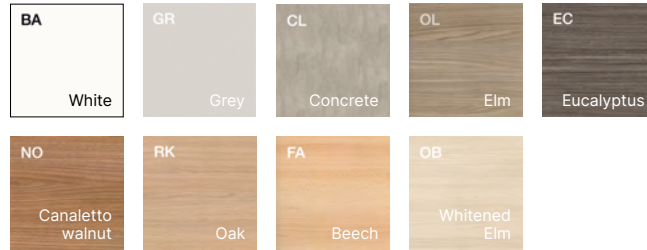

BASE



ø80mm 1.2mm epoxy powder coated steel round tubular legs, 3mm upper plate screws to the top.

Finish options:

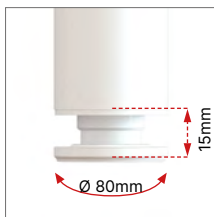

ø80mm polyethylene 0-15mm adjustable levelling feet.

LAYOUT

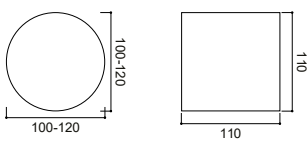



MATERIALS AND RECYCLABILITY

MFC panels used for Meeting Tables range tables are solely manufactured with 100% recycled wood and fully meet requisites of formaldehyde low emissions (CARB Quality Award CATAS Certificate). Rasins used for panels and melamines are free of SVHC substances (to be found in the ECHA list updated as of 12/01/2017).



STANDARDS

Tables with column base have passed the following tests as certified by the **CATAS** Laboratories in San Giovanni al Natisone - Udine, Italy.

- Non domestic tables: safety requirements EN 15372:2008, clause 5
- Stability EN 1730:2000, clause 6.7
- Horizontal static load test EN 1730:2000, clause 6.2
- Vertical static load test EN 1730:2000, clause 6.3
- Horizontal fatigue test EN 1730:2000, clause 6.4
- Vertical fatigue test EN 1730:2000, clause 6.5
- Vertical impact test EN 1730:2000, clause 6.6
- Drop test EN 1730:2000, clause 6.8
- Deflection of table tops UNI 8594:2004



CERTIFICATES

Constantly receptive to market requirements, Quadrifoglio Sistemi d'Arredo pay special attention on quality and safety contents in order to provide high products and services. The Company has reached certifications UNI EN ISO 9001/2015, UNI EN ISO 14001/2015 and UNI EN ISO 45001/2018 to confirm his policy. Our products are certified and ensured by FSC™ and ECOLOGICAL PANEL.

COMPANY WITH
MANAGEMENT SYSTEM
CERTIFIED BY DNV
ISO 9001 • ISO 14001
ISO 45001



GREEN ENERGY

The Company had installed the photovoltaic system with 4.500 solar panels in a 7.350 m² surface that covers almost entirely the factory. The photovoltaic is able to produce 1Mw of a quiet green energy, that does not harm the environment and is waste-free. With his high production capacity the photovoltaic allows us to reduce emissions in the atmosphere of all those polluting substances and to those that contribute to the greenhouse effects. Consequently, such measures make us save every year 180 tonne of petrol oil, 440 tonne of CO₂, 514kg of sulphur dioxide, 448 kg of nitrogen oxide and 23kg of dust.



TRANSPORT

Detachable systems. Volumes that facilitate the optimization of space. Maximum reduction of energy consumption by transport.